



PH-YY10-N0

Features

- 4 ports / 2 cross pol system in high band (3300-3800 MHz)
- Integrated and field replaceable SRET
- ACU HW version: 2.02
- Compliant with AISG v2.0 and 3GPP



PRODUCT OVERVIEW	Frequency Range (MHz)	(2x) 3300-3800	
	Array	■ P1	■ P2
	Connector	1-2	3-4
		4 PORTS	
	Polarization	XPOL	
	Azimuth Beamwidth (avg)	65°	
	Electrical Downtilt	2-12°	
Dimensions	1000 x 180 x 115 mm (39.4 x 7.1 x 4.5 in)		

ORDERING OPTIONS Select from the following ordering options

ANTENNA MODEL NUMBER	CONFIGURATION	MOUNTING HARDWARE	MOUNTING PIPE DIAMETER	SHIPPING WEIGHT
PH-YY10-N0	ACU-I20-B2 Internal RET Included	APM50-B3 Beam Tilt Kit Included	60-110 mm (2.4-4.3 in)	11.4 kg (25.1 lbs)





PH-YY10-N0

ELECTRICAL SPECIFICATIONS

■ P1

Frequency Range		MHz	3300-3800	
		MHz	3300-3600	3600-3800
Polarization		---	±45°	
Gain	Over all Tilts	dBi	16.9 ± 1.0	17.1 ± 0.5
	Max Gain	dBi	17.9	17.6
Azimuth Beamwidth (3 dB)		degrees	68.5° ± 3.5°	64.3° ± 4.6°
Elevation Beamwidth (3 dB)		degrees	6.1° ± 0.4°	6.0° ± 0.1°
Electrical Downtilt		degrees	2-12°	
Impedance		Ohms	50Ω	
VSWR (Return Loss)		---	1.5:1 (-14 dB)	
Passive Intermodulation 3rd Order for 2x20 W Carriers		dBc	-150	
Front-to-Back Ratio, Total Power, ± 30°		dB	22	24
First Upper Side Lobe		dB	18	20.3
Cross-Pol Over Sector		dB	10	9.9
Cross Polar Discrimination (XPD) at Mechanical Boresight (0°)		dB	18	18
Maximum Effective Power Per Port		Watts	200 W	
Cross Polar Isolation		dB	26	26
Interband Isolation		dB	26	26

ELECTRICAL SPECIFICATIONS

■ P2

Frequency Range		MHz	3300-3800	
		MHz	3300-3600	3600-3800
Polarization		---	±45°	
Gain	Over all Tilts	dBi	16.9 ± 1.0	17.1 ± 0.5
	Max Gain	dBi	17.9	17.6
Azimuth Beamwidth (3 dB)		degrees	68.5° ± 3.5°	64.2° ± 4.4°
Elevation Beamwidth (3 dB)		degrees	6.2° ± 0.5°	6.0° ± 0.1°
Electrical Downtilt		degrees	2-12°	
Impedance		Ohms	50Ω	
VSWR (Return Loss)		---	1.5:1 (-14 dB)	
Passive Intermodulation 3rd Order for 2x20 W Carriers		dBc	-150	
Front-to-Back Ratio, Total Power, ± 30°		dB	22	23
First Upper Side Lobe		dB	19	24
Cross-Pol Over Sector		dB	10	10
Cross Polar Discrimination (XPD) at Mechanical Boresight (0°)		dB	17.1	18
Maximum Effective Power Per Port		Watts	200 W	
Cross Polar Isolation		dB	26	26
Interband Isolation		dB	26	26



PH-YY10-N0

BOTTOM VIEW - LABELING

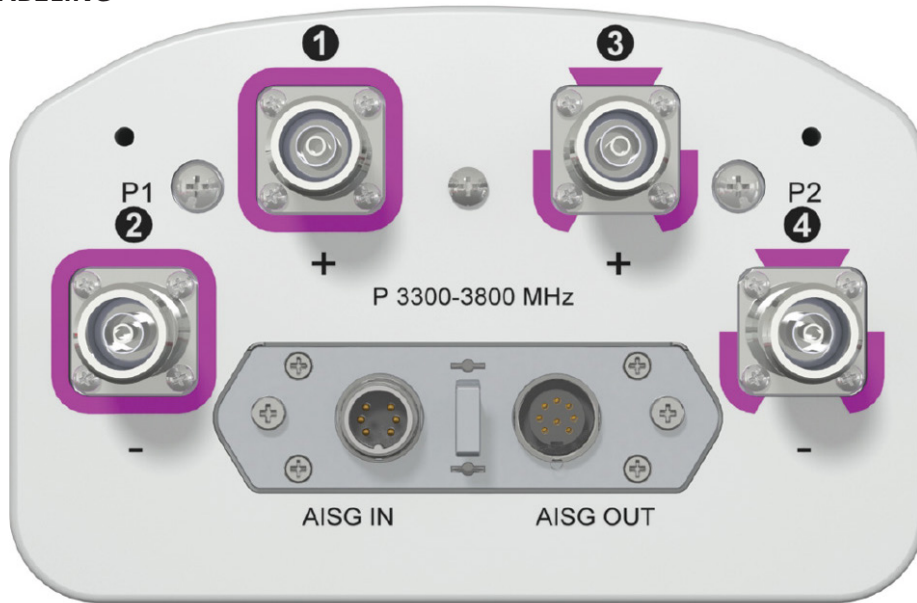

ARRAY LAYOUT

ARRAY	FREQUENCY	CONNECTOR	CONNECTOR TYPE	RET	AISG RET UID
■ P1	3300-3800 MHz	1-2	(2x) 4.3-10 Female	P1	RFxxxxxxxxxx-2P1
■ P2	3300-3800 MHz	3-4	(2x) 4.3-10 Female		



The illustration is not shown to scale.



PH-YY10-N0

MECHANICAL SPECIFICATIONS

Length	mm (in)	1000 (39.4)
Width	mm (in)	180 (7.1)
Depth	mm (in)	115 (4.5)
Net Weight - Antenna Only	kg (lbs)	6.4 (14.1)
Net Weight - Mounting Hardware Only	kg (lbs)	2.7 (6)
Wind Load Rated at 150 km/h (93 mph)	Front	N (lbf) 221 (50)
	Side	N (lbf) 121 (27)
	Rear	N (lbf) 329 (74)
Survival Wind Speed / Rated Wind Speed	km/h (mph)	200 (150)
Connector Type	--	(4x) 4.3-10 Female, (2x) AISG Connectors (1 Male, 1 Female) at Bottom
Radome Color	---	Light Grey RAL7035
Radome Material	---	UPVC
Lightning Protection	---	Direct Ground
Shipping	Packing Size (Length x Width x Depth)	mm (in) 1225 x 275 x 220 (48.2 x 10.8 x 8.7)
	Shipping Weight	kg (lbs) 11.4 (25.1)

ENVIRONMENTAL SPECIFICATIONS

Environmental Standard	---	ETS 300 019
Operating Temperature	degrees	-40° to +60° C (-40° to +140° F)
Product Environmental Compliance	---	Product is RoHS Compliant



PH-YY10-N0

ACCESSORIES

Accessories may be ordered separately unless otherwise indicated.

ITEM	MODEL NUMBER	WEIGHT
Beam Tilt Mounting Bracket Kit for Pole Diameter 60-110 mm (2.4-4.3 in) <i>Shipped with antenna</i>	APM50-B3	2.7 kg (6 lbs)

INSTALLATION

Please read all installation notes before installing product.



- Always attach the antenna using all mounting points.
- Do not install antenna with the connectors facing upwards.

EXTERNAL DOCUMENT LINKS

[APM50 Mounting Kit Series Installation Instructions](#)

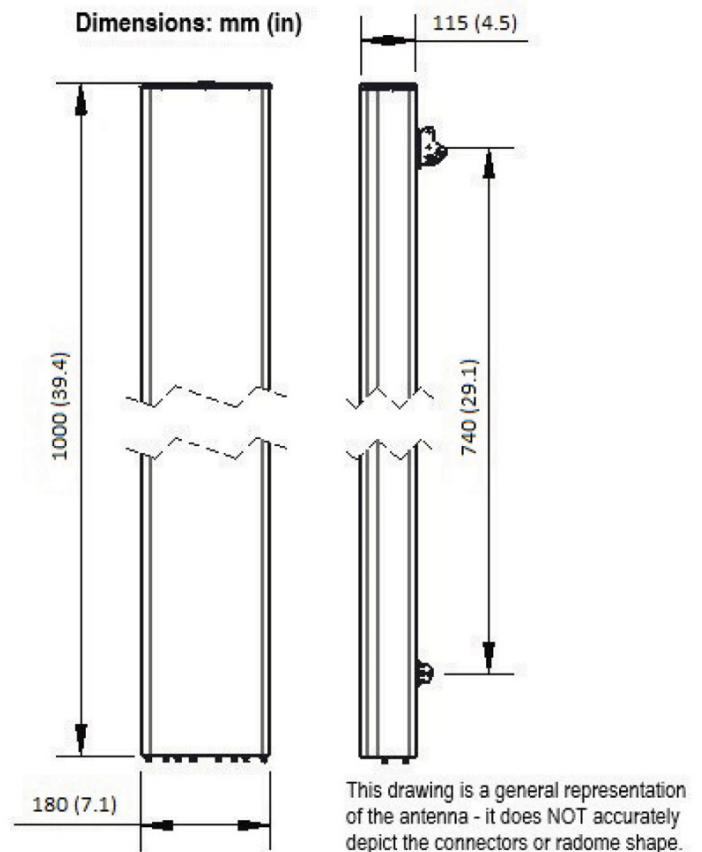

NOTES

- Specifications follow BASTA guidelines.
- For additional mounting information, please check **External Document Links**.
- For Radiating Patterns: [Request pattern files](#)